

Cable Block Hanger, Single Type, for 1/2 in Superflex Cable

- Easy and quick installation
- Robust design & material for outdoor / indoor use

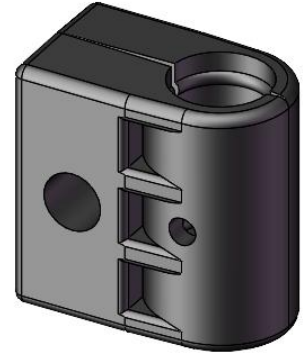

Product Classification

Material Number	6000599
Part Number	-
Status	Active
Detail Description	Block hanger for 1/2 in superflex cable, single run

General Specifications

Material	PP
Color	Black
Mounting	Mounting hole for M8 threaded rod

Dimensions

Height	1.417 in 36 mm
Width	0.866 in 22 mm
Length	1.398 in 35.5 mm
Compatible Cable Jacket OD, maximum	0.551 in 14 mm
Compatible Cable Jacket OD, minimum	0.512 in 13 mm
Normal Size	1/2S

Environmental Specifications

Operating Temperature	-40 °C to +85 °C (-40 °F to +185 °F)
Environmental Strength Capability	Double cable weight
UV Resistance	≥1000 hours, base on ISO4892.3-1994

Packaging and Weights

Bag,Height	1.417 in 36 mm
Bag,Width	5.512 in 140 mm
Bag,Length	7.874 in 200 mm

For more information, please visit:
www.maxdao.com



©Copyright 2023 Maxdao Inc. All rights reserved.

The information contained herein is subject to change without notice. We reserve the right to make technical changes or modify the contents of this document without prior notice.

Revised: Mar 9, 2023
 Public

Included	Double Block Hanger
Packaging quantity and UOM	Kit of 10
Weight, gross	0.243 lb 0.11 kg

Certifications and Compliance

ISO 9001:2015	Designed, manufactured and/or distributed under this quality management system
ROHS	Compliant

